

DASH NO. DESCRIPTION MADE FROM

STAMP: KINGS KA-19-83
PAT. 3195098

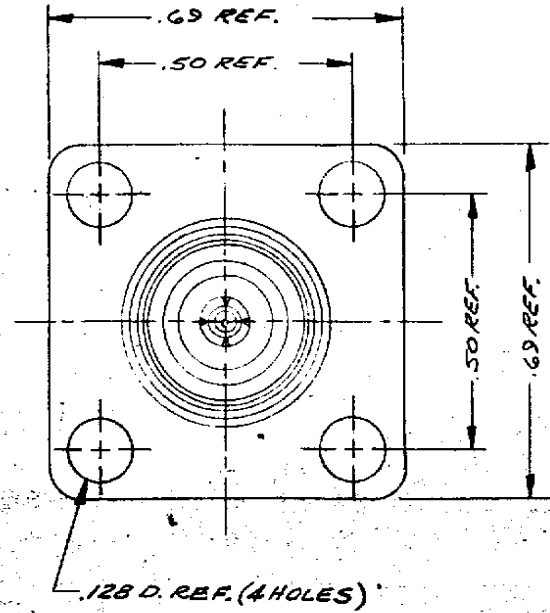
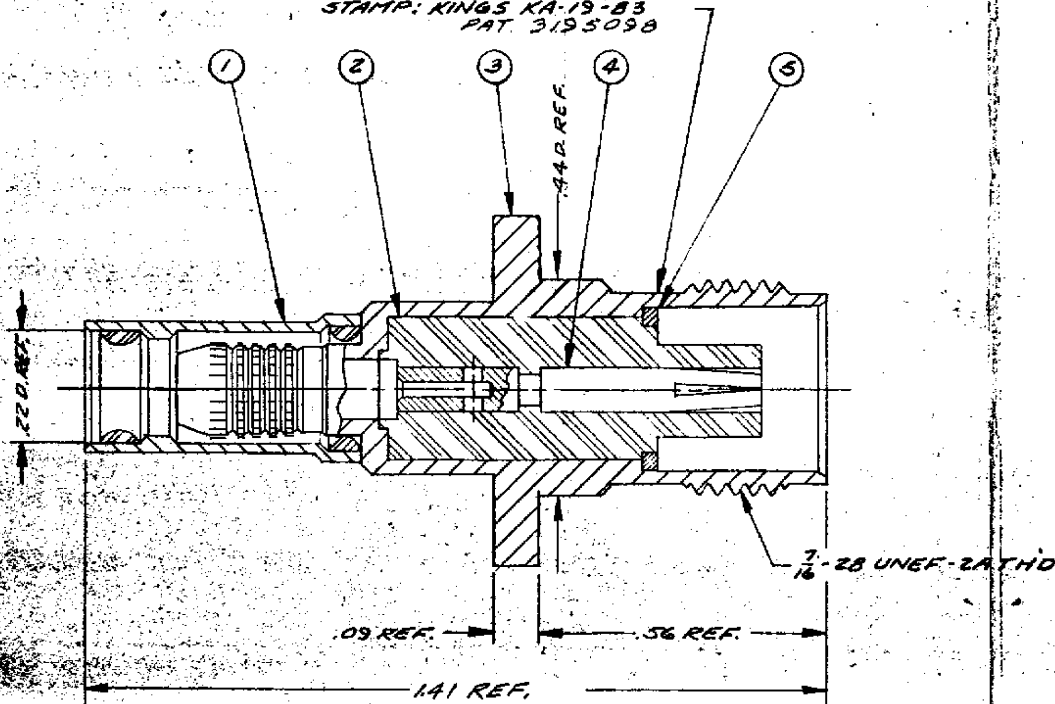

NOTES:

1. FOR USE WITH BA-13077A, BA-14349 & TIMES MI 5406 CABLE.
2. FOR CABLE TRIMMING USE KTJ-149 & KTD-160.
3. FOR FORMING USE CRIMP DIE SIZE 161.
4. FOR CABLEING INSTRUCTIONS SEE CP-5401.
5. JTEA: ① TO HAVE FM27 (RUBBERIZE) AFTER PLATING.

UNLESS OTHERWISE SPECIFIED:

- | | |
|--|--|
| 1. TOLERANCES: FRACTIONS & 2 PLACE DECIMALS ± .010 | 2. REMOVE ALL BURRS, BREAK SHARP EDGES .005 MAX. |
| 3 PLACE DECIMALS ± .004 | 3. NO FILLETS PERMITTED. |
| T. I. R. CONCENTRICITY OF ANY 2 DIAMETERS MAY NOT EXCEED HALF THE SUM OF THEIR TOLERANCES. | 4. SURFACE ROUGHNESS 63 MICRONS RMS MAX. |
| | 5. ALL DIMENSIONS PRIOR TO PLATING. |

REVISIONS

ISSUE	CHANGES
0	ER 13436 JL 28 MAY 75
1	CN 14958A GA 27 OCT 75
2	CN 15668C JHP 7 MAY 76
3	CN 16106E KNURL SHOWN, K-GRIP SLEEVE SHORTENED MJB 23 JUL 76
4	CN 29033D AMD 23 JUN 87
5	CN 29609E KH 11 FEB 88
6	CN 30083E JCA 15 AUG 88

KA-19-83

USED ON:

REF:

FINISH:

SPEC:

MATL:

SPEC:

TNC PANEL JACK

DRAWN JL DATE 2 DEC 74
APPR. LI DATE 29 MAY 75

KINGS ELECTRONICS
40 MARLBOROUGH ROAD
TUCKAHOE, N. Y. 10707

KA-19-83

ITEM	REQ'D	DESCRIPTION	PART NO.
5	1	RETAINING RING	
4	1	BNC CAPTIVE CRIMP CONTACT F	1-507-3AMAD
3	1	K-GRIP BODY ASS'Y	
2	1	INSULATOR	
1	1	W/P K-GRIP SLEEVE (SEE NOTE)	A-19-83-2-M06